

## Electric Column Car

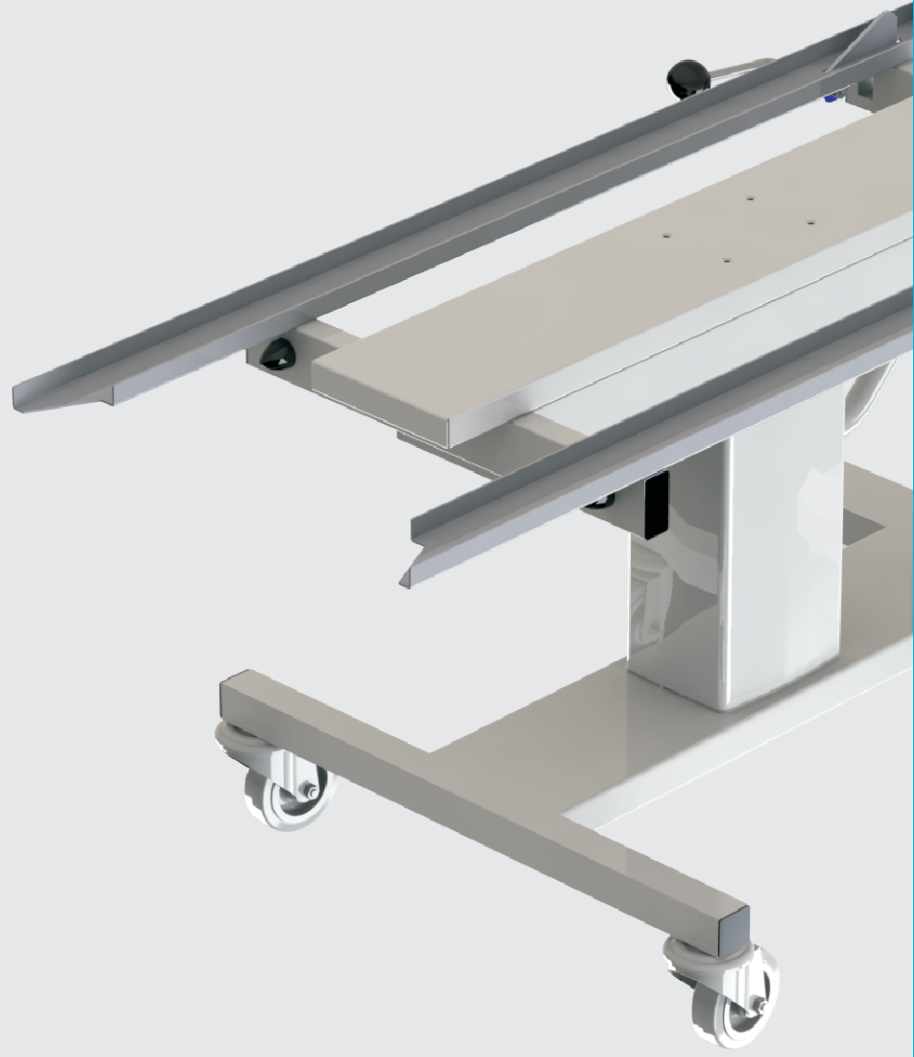

# Electric Column Car

The Electric Column Car is robust and easy to handle.

With two versions available - column static and electro-hydraulic, this car can be adapted to several features of hospital, veterinary and laboratory use.

## Technical Characteristics

- Fully built in AISI 304 stainless steel.
- Large load capacity and versatility.
- Sliding platform with brake.
- Electric Lifting Column.
- Locking lever.
- Four swivel wheels with brake.
- Maximum elevation: 940mm
- Minimum elevation: 535mm

## Note

-Dimensions are variable according to the sterilizer model.

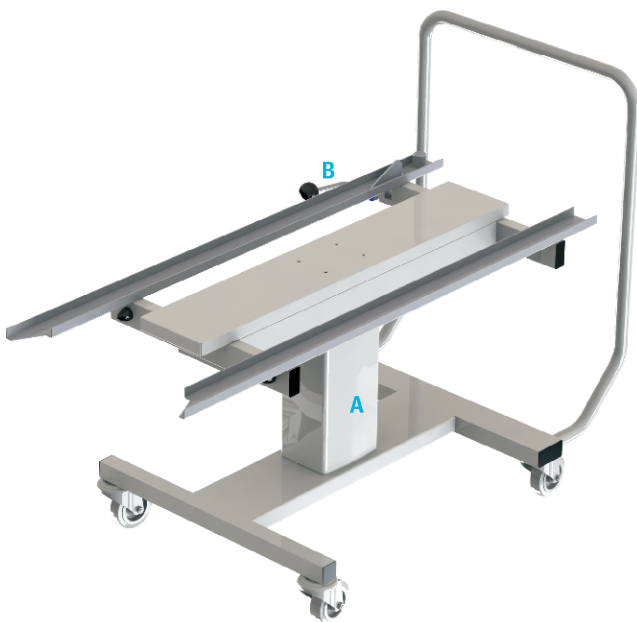

A



B

Due to product improvement and development, PROHS reserves the right to make changes without notice.